

INVESTIGATING THE ROLE OF ENVIRONMENTAL MANAGEMENT EXERCISES ON THE SUSTAINABILITY OF SPORTS BUSINESSES

Mohammad Reza Ghasemi
Rezaghaseemi74@gmail.com
Islamic Azad University

Ebrahim Khoshnam
khoshnam9696@gmail.com
Islamic Azad University

Ahmad Tork Far
a.torkfar@gmail.com
University of Jahrom, Iran

Younes Mohammadzadeh
younesmohammadzadeh598@gmail.com
Zand University, Shiraz, Iran

ABSTRACT

The present study aims to investigate the role of environmental management training on the sustainability of sport businesses. The method of this study was a survey for collecting data. The statistical population of this research includes all managers of sports businesses in Tehran in the amount of 1500 enterprises. Accordingly, 306 managers of these companies were identified as the sample of the study. The research tool was a questionnaire used in the conceptual model of Bough et al. (2018). The structural equation method was used to analyze the data of the present study. The entire research analysis process was conducted using SPSS version 20 and PLS version 2 software. The results of this study showed that operational, communicational, organizational, and supplementary exercises have a significant effect on the sustainability of sports businesses.

Keywords: Business, Sustainability, Sports, Environment.

1. INTRODUCTION

One of the issues of the world today is the environmental protection, which has been acknowledged and emphasized not only as an integral part of sustainable development but also as an essential value of today's and future generations (Jabber, 2015). Instability instances such as inappropriate use of energy, overuse and destruction of basic resources, poverty, population growth, pollution, etc. are also major environmental problems, and inevitably environmental protection and sustainable development are increasingly important (Zhu et al., 2017). With the advent of technology, human problems have become more widespread, making biological disorders as one of the most important concerns of the world today. Numerous environmental issues have engulfed the minds and paved the way for further efforts to put in place policies that focus more on the environment (Di Giacomo et al., 2017).

The importance of a healthy environment today and the need to strive to preserve it is not hidden. Protecting the planet's environment is not possible without the participation of all countries and their people. For this reason, international legal instruments such as the Rio Declaration, Agenda 12, have emphasized the principle of public participation in environmental protection (Renwick et al., 2013). Studying these documents and summarizing them will determine the three elements required for public participation. These three components are: The right to access environmental information, public participation in the decision-making (and its process), as well as access to and use of environmental judicial authorities in the field (Jabbour, 2013). The importance of paying attention to the environment in organizations has led many organizations to have a well-devised plan for environment and ecosystems. However, in this way, human resources as a strong force in organizations can change the extent to which the organization achieves its environmental goals (Tateyan et al., 2009).

Organizations face the inevitable requirements to meet the challenge of environmental protection. Proper environmental management has become a success factor for organizations (Kramar, 2014). One of the major goals of organizations is to continually improve the environmental status while quantitatively developing capacity and increasing the diversity and quality of products and services (Tao et al., 2016). The implementation of an environmental management system, in spite of unstable economic conditions and difficult environmental laws and regulations in most organizations aims to improve their environmental performance in accordance with the laws and regulations and increase their competitiveness in global markets (Wagner, 2013). The importance of environmental performance in organizations has led to an in-depth analysis of organizations' environmental performance (Dashti Nezhad et al., 2015).

Business growth is one of the key metrics for evaluating the performance and success of an enterprise. In today's competitive world, companies can no longer rely on a steady trend over a long period of time, and inevitably need continuous growth to survive and maintain their position relative to other firms. This growth can also take place in areas such as sales, market share, asset, human resources, talent pool and the like (Davari & Moradi, 2013). One of the most important issues in any environment is sustainable development.

The central idea of sustainable development is to meet the needs of the present generation, taking into account the needs of future generations. Sustainable development is essential for human progress; therefore, measures must be taken to eliminate the contradiction between development and resource conservation so that existing resources, as well as development, are out of order and controllable. Developing international businesses also contributes to the economic growth of a country and attracts foreign investment, with a view to sustainable development. One of the main concerns of the country today is solving the unemployment problem. Due to structural reasons, such as increased labor supply, lack of investment, rural migration to cities, increased participation rates of women in economic activities, increased graduates in universities and young population, Iran's labor market is in imbalance (Ganescu, 2012). Micro-businesses are among the most important employment factors. Therefore, attention to this type of activity has increased today. In many countries, micro-enterprises and businesses play a significant role in employment creation and income distribution (Fellnhofer, 2017).

Business professionals place special emphasis on identifying the elements that affect business sustainability and usually refer to business sustainability in the form of conceptual and descriptive models. The Business Sustainability Model, by creating a common understanding of business logic, analyzing and improving business, and creating a clear vision, allows companies to provide the market with their designs and ideas, and thus enable them to maintain and enhance their position in the domestic and global markets (Kondoh & Mishima, 2011).

Job creation has always been one of the basic needs of societies, which requires a great deal of investment from the government and the private sector. In this context, small businesses, and consequently micro-employment, with the need for minimal capital and based on the entrepreneurial potential of society, enable the efficient and increasing use of resources and assist governments in achieving their goals of job creation and welfare development (Fellnhofer, 2017).

Various studies have examined the role of environmental issues on business. Naderi Bani et al. (2017) found that in order to promote sustainable organizational entrepreneur-

ship in sports organizations, the improvement of some organizational aspects, including cultural, environmental, human and economic issues is needed. Bjärsholm et al. (2018) found that, in order to develop sustainable entrepreneurship in sport, it is needed to pay attention to some important aspects, including environmental issues, which could lead to positive publicity in businesses. Ultimately, these factors make businesses sustainable. Yfantidou et al. (2018) pointed out that some green practices help to promote the business brand by enhancing the environmental status of businesses, which in turn stabilizes sports businesses. Buffa et al. (2018), which aimed at examining the role of environmental management on sustainable businesses in their research, found that environmental management improves business status due to its impact on social and economic aspects, which in turn stabilizes businesses. Moreover, Ratten (2015) pointed out that, in order to be sustainable, home sports businesses need to pay close attention to certain societal values, including environmental issues.

The sport as an active area of the community plays an important role in improving business. The field of sports has much potential that have a crucial role in the development of sustainable businesses if they are analyzed and targeted in a transparent manner. On the other hand, in order to create sustainable businesses, there is a need for many infrastructure issues, as the importance of such businesses has made them one of the most important issues of entrepreneurship and management in different fields. With a large audience size, the sports field has not been able to utilize its potential to grow sustainable businesses. This has led to serious problems in the way of sustainable business development in the field of sports. There are various ways to improve sustainable businesses, one of which is to harness the potential of the environment. This issue in the sport field requires comprehensive and applied research. Hosseini et al. (2017) noted that the environmental aspects of developing sustainable entrepreneurship in sport have not been explored in research. However, research has been carried out in some industrial areas. The lack of research in this area has led to the lack of environmental management currently needed to develop sustainable sports businesses. Therefore, the present study aims to investigate the role of environmental management practices on the sustainability of sports businesses in order to answer the following question: Do the environmental management practices play a role in the sustainability of sports businesses? The conceptual model of Buffa et al. (2018) was used to answer the present research question. Figure 1 illustrates the conceptual model of the present study.

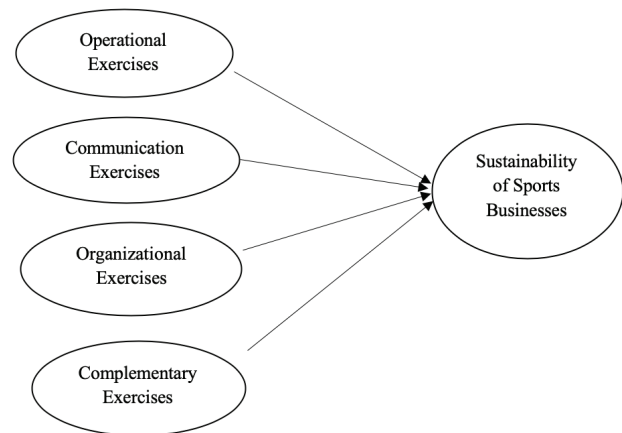

Figure 1. Conceptual Research Model (Buffa et al., 2018)

2. METHODOLOGY

Regarding the method of implementation and data collection, this research is a field study, respectively. As the results of this research were used in sports businesses, it is an applied study. The statistical population of this study includes all managers of sport businesses in Tehran with 1500 businesses. Accordingly, 306 managers of these businesses were selected as the sample of the study. Furthermore, an available sample is recruited as the sampling method. Face-to-face communication, email, and cyberspace were used to communicate with these individuals. After distribution and collection of the questionnaires, 275 of them were analyzed.

In this study, field and library methods were used for data collection. In the library section, by reviewing articles and books in the field of research, the theoretical foundations of research were collected and prepared. A questionnaire was also used to collect research data in the field survey. The research tool was a questionnaire used in the conceptual model of Buffa et al. (2018). The questionnaire generally measures business sustainability (five questions), operational exercises (five questions), communication exercises (three questions), organizational exercises (three questions), and follow-up exercises (three questions).

The questions were designed on a five-point Likert scale. The validity of this questionnaire was examined in the study of Buffa et al. (2018). The reliability of the questionnaire was 0.87. In the present study, the validity of this questionnaire was evaluated using the opinions of academic experts. Moreover, the overall reliability of the questionnaire after Cronbach's alpha was calculated at 0.80. The reliability of the measurement model was evaluated by factor loading coefficients, Cronbach's alpha, and combined reliability. The factor load is calculated through the correlation value of the indices of a structure with that structure. If this value is equal to or greater than 0.4, it indicates that the varian-

ce between the construct and its indices is greater than the variance of the measurement error of the construct and the reliability of that construct is acceptable. Also in relation to the final questionnaire for distribution, content validity was obtained using a survey of 10 sports management experts. Thus, the validity of the content of the research instruments was confirmed. Divergent and convergent validity were also evaluated in this study. Therefore, it can be stated that the present research questionnaire had good reliability and validity. Moreover, in the analysis section of the research, the SEM-PLS approach¹ is used, given that the distribution of the research sample is abnormal according to the Kolmogorov-Smirnov (K-S) statistical method. Therefore, there are prerequisites for using variance-based software and one should use variance-based software, such as PLS (Peng & Lai, 2012, 469). The whole analysis process was performed using SPSS 20 and PLS 2 software.

3. FINDINGS

Descriptive results for age showed that 20.2% of statistical sample were younger than 35 years, individuals with 35-40 years are 39.3%, individuals with 40-50 years are 32.1% and 8.4% are older than 50. Descriptive results related to gender showed that 11.8% of the sample were female and 88.2% were male. The structural equation approach was used to investigate the role of environmental management exercises on the sustainability of sports businesses. Figures 2 and 3 show the results of the structural equations.

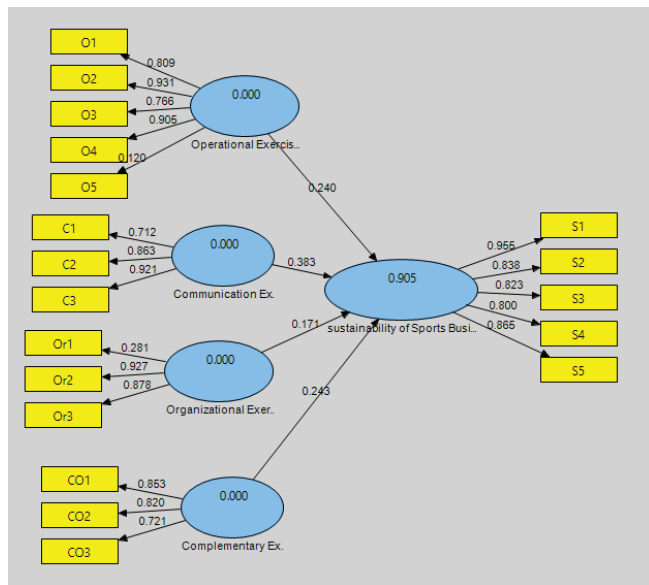

Figure 2. Measuring model

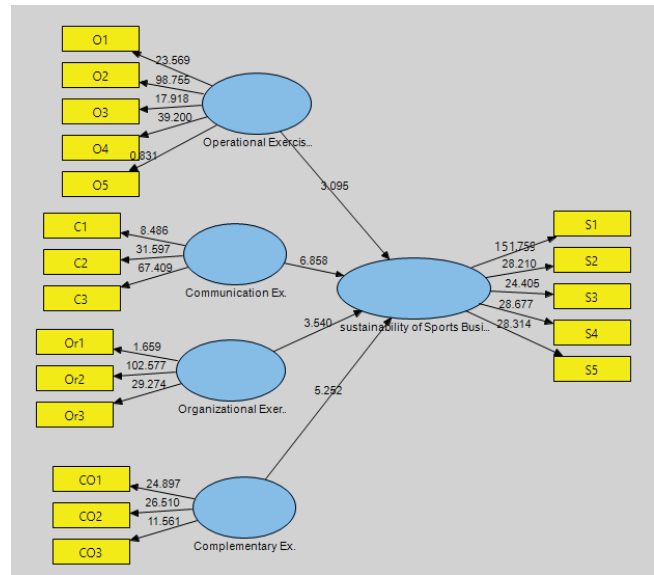

Figure 3. Significant coefficients t of the research model

Table 1. Information of the Research Model

Impact of variables	Impact	t	Sig
Operational Exercises on the sustainability of Sports Businesses	0.240	3.095	0.001
Communication Exercises on the sustainability of Sports Businesses	0.383	6.858	0.001
Organizational Exercises on the Sustainability of Sports Businesses	0.171	3.540	0.001
Complementary Exercises on the sustainability of Sports Businesses	0.243	5.252	0.001

As the results of the study show, operational Exercises has an impact on the sustainability of sports businesses (t = 3.095; impact = 0.240). Also, according to the results of the present study, it was found that communication exercises had an impact on the sustainability of sports businesses (t = 6.858; impact = 0.383). Organizational exercise has an impact on the sustainability of sports businesses (t = 3.540; impact = 0.171) and complementary exercise has an impact on the sustainability of sports businesses (t = 5.252; impact = 0.243). Table 2 shows the fitting index of the model.

4. DISCUSSION

The results of this study indicated that to improve the sustainability of sports businesses, it is necessary to upgrade some environmental aspects, such as operational, communication, organizational and complementary exercises. The present study showed that these exercises, through their potentials and functions, promote and improve the sustain-

1 Structural equation method with partial least squares approach

nability of sports businesses. In other words, to sustain the sports business, some efforts are needed to raise environmental issues through the exercises mentioned above. Bjärsholm et al. (2018) found that doing some environmental activities and institutionalizing them improve entrepreneurship in organizations. Ratten (2015) also found that some bio-management behaviors in sports businesses promote brand sustainability by promoting brand popularity. Buffa et al. (2018) also found that environmental attention from organizations causes customers to be aware of their environmental efforts, which improves the performance of these organizations. Environmental management exercises appear to improve the environmental performance of sports businesses. This issue, as a means of advertising, makes sports businesses more recognizable in their environment. On the other hand, environmental management practices also lead to energy and cost management in sports businesses, which in turn reduces costs in the long run, making sports businesses sustainable.

The results of this study showed that among environmental management exercises, communication exercises play a more important role for the sustainability of sports businesses. Communication exercises allow enterprises to implement environmental businesses, as well as activities and programs in the environment field, and this output is transmitted to the surrounding environment. Buffa et al. (2018) identified that achieving optimal performance by promoting environmental management is needed to communicate the results obtained through environmental management at the community level. Communication exercises appear to play a prominent role in environmental management activities, causing different groups to become familiar with the environmental performance of sports businesses, which can be recognized as a major advertisement in business.

Environmental management can have a positive impact on different aspects of business through its functions and the key role it plays in the cultural, financial and social trans-

formation of organizations and companies. This has led to the improvement of environmental management as one of the most important issues in the field of entrepreneurship. Therefore, conducting comprehensive research on improving the efficiency of environmental management to promote sustainable business in sport will enable us to pursue the path of entrepreneurship development in sport as well as the formation and creation of sustainable sports businesses. According to the results of the present study, it is suggested that sports businesses increase their activity in the field of environment by creating departments, committees or human resources. Also, according to the results of the present study, it is suggested that sports businesses regularly report on their activities in the environment field. Furthermore, according to the results of the present study, it is suggested to use some human resources outside of the sports business to enhance some marketing activities, including green marketing. Based on the results of this study, it is suggested that the use of some renewable resources in consumables in sports businesses will help reduce energy and material costs in the organization.

REFERENCES

- Arbitration, Ali; Shahbaz Moradi, Saeed. (2013). Identifying the Impact of Entrepreneurial Orientation and Organizational Factors on Business Performance (Case Study: Technical Companies Affiliated with National Iranian Oil Company). *Journal of Entrepreneurship Development*, Volume 6, Issue 3, pp. 125, 143.
- Bjärsholm, D., Gerrevall, P., Linnér, S., Norberg, J. R., Peterson, T., & Schenker, K. 2018. A Methodological Tool for Researching Sport and Social Entrepreneurship. In *Sport and Social Entrepreneurship in Sweden* (pp. 113-122). Palgrave Macmillan, Cham.
- Buffa, F., Franch, M., & Rizio, D. 2018. Environmental management practices for sustainable business models in small and

Table 2. Fitting indexes of the model

Fitting indexes	sustainability of Sports Businesses	Operational Exercises	Communication Exercises	Organizational Exercises	Complementary Exercises
Cronbach's alpha	0.90	0.79	0.81	0.87	0.77
Combined reliability	0.93	0.87	0.84	0.77	0.85
Convergent validity	0.73	0.69	0.63	0.56	0.58
R2	0.90	-	-	-	-
Q2	0.73	0.69	0.63	0.56	0.58
GOF*	0.810	-	-	-	-

*Goodness of fit

According to the reported indices, it was found that the present model has a good fit.

- medium sized hotel enterprises. *Journal of Cleaner Production* 194, 656-664.
- Dashti Nezhad, Yousef; Azarshah, Ali; Chegini, Hossein. 2015. Problems of Barriers to Private Sector Human Resources Education in the Environment, Second National Congress of Biology and Natural Sciences, Tehran, Sustainable Development Solutions Center and Mehr Arvand Institute of Higher Education.
- Di Giacomo, N., Di Giacomo, N., Guthrie, J., Guthrie, J., Farneti, F., & Farneti, F. 2017. Environmental management control systems for carbon emissions. *PSU Research Review* 1, 39-50.
- Fellnhöfer, K. 2017. Drivers of innovation success in sustainable businesses. *Journal of Cleaner Production* 167, 1534-1545.
- Ganescu, M. C. 2012. Corporate social responsibility, a strategy to create and consolidate sustainable businesses. *Theoretical & Applied Economics* 19.
- Hosseini, Abolhassan; Razavi, Seyed Mohammad Hossein; Ashouri, Taghi; Dosti, Morteza. 2017. Content Analysis of Sport Entrepreneurship Boards in Iran, *Applied Research in Sport Management*, 6th Winter 2016, Number 3 (23rd consecutive)
- Jabbour, C.J.C., Jabbour, A.B.L.S., Govindan, K., Teixeira, A. A., Freitas, W.R.S. (2013). Environmental management and operational performance in automotive companies in Brazil: the role of human resource management and lean manufacturing. *Journal of Cleaner Production*, 47, 129-140.
- Kondoh, S., & Mishima, N. 2011. Proposal of cause-effect pattern library for realizing sustainable businesses. *CIRP Annals-Manufacturing Technology* 60, 33-36.
- Naderi Bani, M., Ebrahimzadeh, R., Abolghasemi, M., Maliki Nejad, P. 2017. Designing a Conceptual Model of Organizational Entrepreneurship Achievement with Integrated Approach of Mikhailov Fuzzy Hierarchical Analysis and Interpretive Structural Modeling (Case Study: Yazd Province Sport and Youth Organization), *Applied Research in Sport Management* Sixth Winter, No. 3 (23rd consecutive)
- Peng, D., & Lai, F. 2012. Using partial least squares in operations management research: A practical guideline and summary of past research. *Journal of Operations Management* 30, 467-480.
- Ratten, V. 2015. Family business in sport organizations: Western experiences as lessons for transitional economies. In *Family businesses in transition economies* (pp. 305-317). Springer, Cham.
- Renwick, D. W., Redman, T., & Maguire, S. 2013. Green human resource management: A review and research agenda. *International Journal of Management Reviews* 15, 1-14.
- Tao, Y., Li, F., Crittenden, J. C., Lu, Z., & Sun, X. 2016. Environmental impacts of China's urbanization from 2000 to 2010 and management implications. *Environmental Management* 57, 498-507.
- Tateyan, M. R., Tamartash, R., Yousefian, M. 2009. Evaluation of the damaging effects of human activities on the environment in Mazandaran province, Third Specialized Conference on Environmental Engineering, Tehran University, Tehran, Iran
- Wagner, M. 2013. 'Green' human resource benefits: do they matter as determinants of environmental management system implementation? *Journal of Business Ethics*, 1-14.
- Yfantidou, G., Spyridopoulou, E., Papaioannou, A., & Balaska, P. 2018. The Interest of Sport Tourism Enterprises in Green Practices. In *Innovative Approaches to Tourism and Leisure* (pp. 275-287). Springer, Cham.
- Zhu, Q., Feng, Y., & Choi, S. B. 2017. The role of customer relational governance in environmental and economic performance improvement through green supply chain management. *Journal of Cleaner Production* 155, 46-53.

Received: Feb 18, 2020

Approved: Feb 26, 2020

DOI: 10.20985/1980-5160.2020.v15n1.1618

How to cite: Ghasemi, M.R., Khoshnam, E., Far, A. T. et al. (2020), Investigating the role of environmental management exercises on the sustainability of sports businesses, *Revista S&G* 15, No. 1, 53-58. <https://revistasg.emnuvens.com.br/sg/article/view/1618>